



MARETTI

L I G H T I N G



Maretti Lighting
Bolderweg 7

1332 AX Almere
the Netherlands

T +31 (0) 36 532 66 12
F +31 (0) 36 532 17 35

E info@maretti.com
W www.maretti.com

Maretti Lighting is well-known in the World of interior design. In businesses, homes, store chains, and hospitality facilities all over the world, Maretti is unmistakable present with its project lighting that does more than just provide light. We make lighting an essential part of the interior. Maretti stands for stylish top quality and trendsetting design, modern, timeless and most of all, original.

Maretti Lighting works with all the top brands in the lighting industry, but we are especially notable for our own large product line and introduce our own brand name "Maretti". Our production team distinguishes itself time and time again with unique innovations from our own atelier and therefore our projects exude an entirely unique identity.

© Copyright Maretti Projectverlichting.

Our IM was made with the greatest of care. Nevertheless, the colours displayed in the IM may differ slightly from the real colours because of the printing process. Colour, size and range are subject to change. Nothing from this IM may be copied, reproduced and/or published by print, photocopy or in any other way without Maretti Lighting's written permission. All product and design copyrights belong to Maretti Lighting.

GUARANTEE TERMS AND CONDITIONS

The other party should inspect the delivered items immediately upon receipt with regard to its soundness. Entitlements to repair or replacement only exist if the other party

- In the case of visible defects, informs MPV of them immediately.

- In the case of defects that are not visible, informs MPV in writing of the defects, within 2 working days after the day the defects were found, or in all reason could have been found and furthermore demonstrates that the MPV instructions for use, maintenance and operation were followed, whilst the defects are not the consequence of normal wear and tear, misuse, negligence, accident, exceeding the limits prescribed by the MPV or by the legal safety regulations, or, in the case of a repair or change without MPV's consent or the consent of its recognised repairer, there will be no entitlement to repairs or replacement. The parts that have to be replaced must be made available free of charge to MPV. Noncompliance by the other party to one or more of its obligations will release MPV of all its guarantee obligations. In the case of assembly of the other party's own products by Maretti, MPV will release itself from all guarantee stipulations. Moreover, our general delivery terms and conditions are applicable. These can be obtained from Maretti or can be downloaded from www.maretti.com

The installation must be done by a competent installer. Maretti recommends that your (outside) lighting and fixtures are inspected and maintained annually.

D: Für Garantiebedingungen bitte lesen Sie unsere Webseite www.maretti.com
E: Consulte nuestro sitio web para los condiciones de garantía www.maretti.com
FR: Consultez notre site web pour les conditions de garantie www.maretti.com
NL: Voor garantievoorwaarden zie onze website www.maretti.com

21.8230.82

CUSCO FLAT LED P&P AR70



36V DC	VOLTAGE	2Pins P&P	FITTING	30.000 uren	LEVENSDUUR LED	99-99.5%	LUMEN-BEHOUD		
5,8W	WATTAGE	300 lm	LUMEN	100000	SCHAKEL-CYCLUS		GRADEN BUNDEL 24°		
	LED LICHTBRON		CTA 2000-2700K	<0,5s	OPWARMTIJD TOT 60%		CE MARK		
160 mA	MILLIAMPERE	Ra97	CRI	-30~+40°C	OMGEVINGS-TEMPERATUUR				

CUSCO FLAT LED P&P AR70

INSTRUCTIONS

DRIVERS: APART VERKRIJGBAAR / SEPARATE ORDER

ART. NR.	NAAM / NAME	WATTAGE	MILIAMPER	DIMMEN / DIMMING	AANSLUITING / CONNECTION	AANTAL LICHTBRONNEN / NUMBER OF LIGHT BULBS
16.8100.0160.E*	DRIVER P&P	6W	160mA	Fase aan- afsnijding / Tronic	2m kabel eurostekker	1
16.8100.0160.G*	DRIVER P&P	6W	160mA	Fase aan- afsnijding / Tronic	2m kabel GST18	1
16.8100.0160.W*	DRIVER P&P	6W	160mA	Fase aan- afsnijding / Tronic	2m kabel WINSTA	1
16.7000.0160.Z*	DRIVER DALI INTEL P&P	0,4W – 7,2W	160mA	CTA/AM dimbaar	2m kabel excl. prim. connector	1
16.7000.0160.G*	DRIVER DALI INTEL P&P	0,4W – 7,2W	160mA	CTA/AM dimbaar	2m kabel GST18 connector	1
16.7000.0160.W*	DRIVER DALI INTEL P&P	0,4W – 7,2W	160mA	CTA/AM dimbaar	2m kabel WINSTA connector	1
16.7105.0160.G*	DRIVER DALI DUO P&P	2x 8,8W	160mA	CTA/AM dimbaar	GST18 5-polig / 1 DALI adres 2x uitgang	2
16.7105.0160.W*	DRIVER DALI DUO P&P	2x 8,8W	160mA	CTA/AM dimbaar	WINSTA 5-polig / 1 DALI adres 2x uitgang	2
16.7105.0160.Z*	DRIVER DALI DUO P&P	2x 8,8W	160mA	CTA/AM dimbaar	excl. prim. connector / 1 DALI adres 2x uitgang	2

E: Europlug
G: GST18
W: Winsta
Z: Geen plug

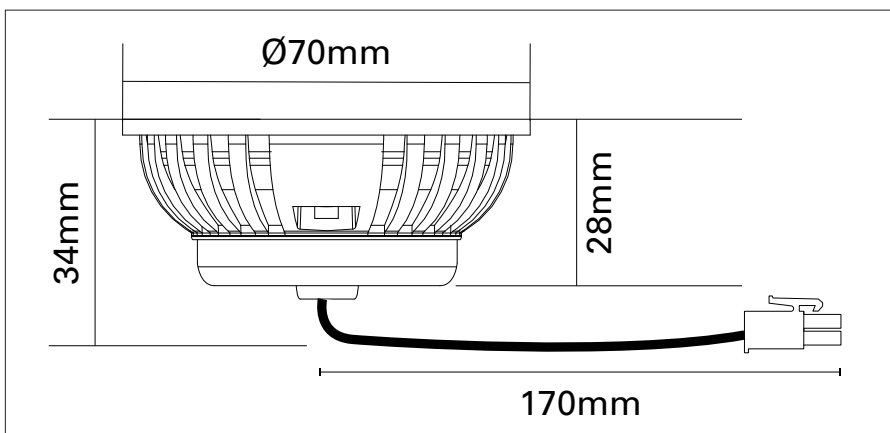
**LET OP:**

- Volg en bewaar deze gebruiksaanwijzing.
- Zorg ervoor dat de netspanning uitgeschakeld is voor installatie, reparatie of onderhoud. (Installatie, reparatie en onderhoud uitsluitend door gekwalificeerde personen).
- Voor reparatie of onderhoud uitsluitend originele delen gebruiken.
- Gebruik het product alleen binnenshuis.

De fabrikant aanvaardt geen enkele aansprakelijkheid voor letsel of schade als gevolg van een verkeerde toepassing van het armatuur. De fabrikant aanvaardt geen garantie in geval van het niet behandelen van de lampen volgens de richtlijnen van de fabrikant. Als er schade aan elektrische onderdelen te vinden zijn, vraag dan een elektricien om het te vervangen.

Onderhoud is behoud:

Een goede instandhouding van het armatuur is sterk afhankelijk van omgevings- en onderhoudsfactoren. Hierop kunnen wij geen invloed uitoefenen.

NOTE:

- Follow and keep this instructions manual.
- Make sure that the mains voltage is switched off for installation, reparation or maintenance. (Installation, reparation and maintenance only by qualified persons).
- Use only original parts for repairs or maintenance.
- Use the product only indoors.

The manufacturer accepts no liability for any injuries or damages resulting from the incorrect use or installation of the fixture. Any operation performed on the fixture that is not in accordance with instructions will void manufacturer's warranty. If you find any damage to the electrical parts, please ask a qualified electrician to replace it.

Maintenance is preservation:

A good preservation of the fixture is highly dependent on environmental factors and maintenance. We cannot exercise any influence on this.

MARETTI LIGHTING
 21.8230.82

A
 B
 C
 D
 E
 F
 G

WXYZ
 kWh/1000h

 2019/2015